

In order to pilot with your Smalltrack – security system of tracking by satellite – you will need to fix your bracket according to the recommendations of this document. In the Dakar 2018 configuration, you will not need antennas nor power cable for your Smalltrack.

THE SMALLTRACK AND IT'S BRACKET



The white zone indicates the antennas position.

BRACKET INSTALLATION AND FIXATION

You will find below the dimensions and the drilling patterns. :

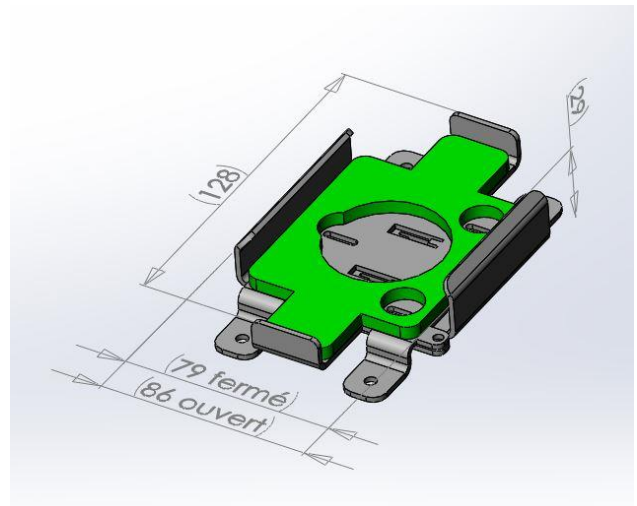
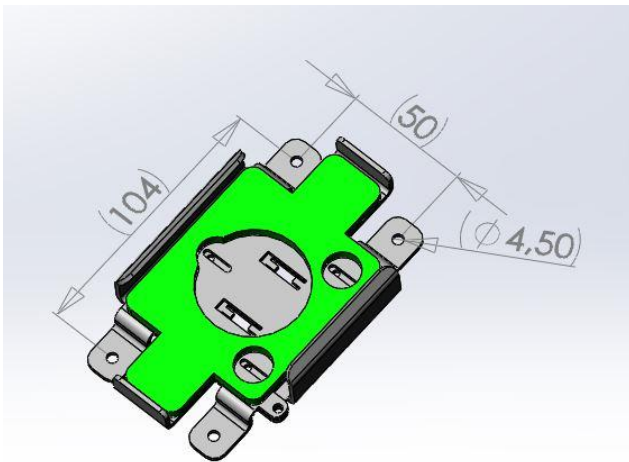

The total height of the Smalltrack, when it is installed in the bracket is 50mm (29mm for the bracket only).
The bracket needs to be fixed to the bike or to the quad by the 4 fixations points.

⚠ IMPORTANT

During the bracket fixation it is necessary to remind that:

- You need to see the buttons and access them easily
- The up side must not be masked, and needs a clear view on the sky (for the internal antennas)
- Le support doit être le plus à horizontal possible (angle de 0 à 50° maximum)

EXEMPLE OF INSTALLATION



On a slab, fixed on the navigation column

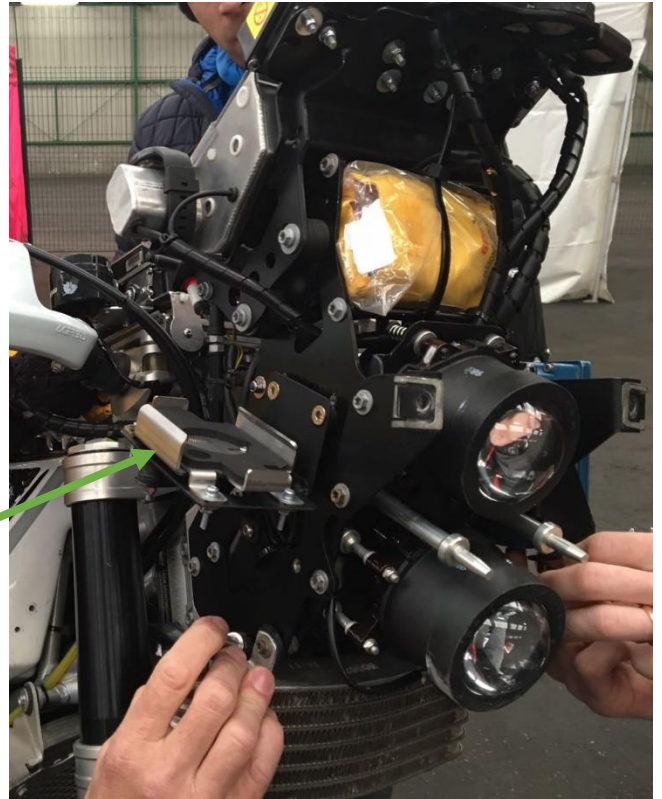

Near to the Antenas, under the bubble (*)

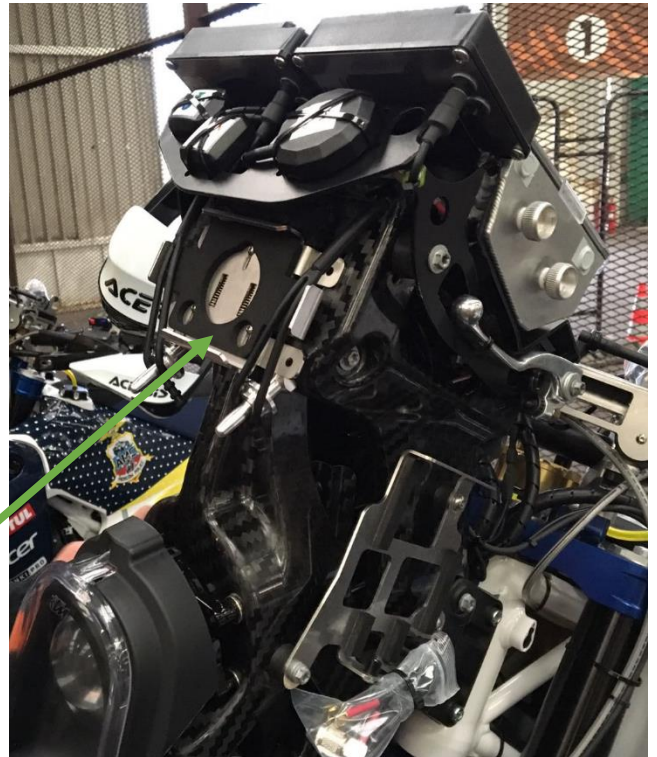

(*) These 2 pictures simply illustrate a possibility of location. In this case, the bracket is not fixed to the bike, and the angle can be optimized during the final fixation.

This installation is not conform : the bracket's fixation angle is over 90°.



INTRODUCTION OF THE SMALLTRACK IN IT'S BRACKET

A spring system will lock the Smalltrack in the bracket. In order to secure the installation, there is an eyelet of fixation designed to receive a Rilsan type clamp.

As illustrated below :

- Insert the Smalltrack in the bracket by the spring side.
- Push in order to move aside the removable part of the bracket.
- Then engage the other side by pushing it down in the bracket.



Push the SmallTrack in the bracket



SmallTrack correctly inserted in the bracket.



114/126, avenue d'Alfortville - 94600 CHOISY LE ROI - France - Tél : +33 (0)1 48 84 34 00 Fax : +33 (0)1 48 52 53 54
S.A.S. au capital de 236 400€ - Code TVA FR 26 334 306 172 - Code APE 5912 Z - SIREN 334 306 172 00084 - RC 334 306 172
www.marlink.com - services.events@marlink.com